

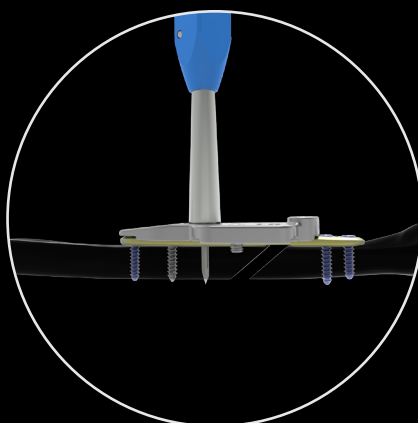

NEWCLIP-TECHNICS

INNOVATION MEANS MOTION

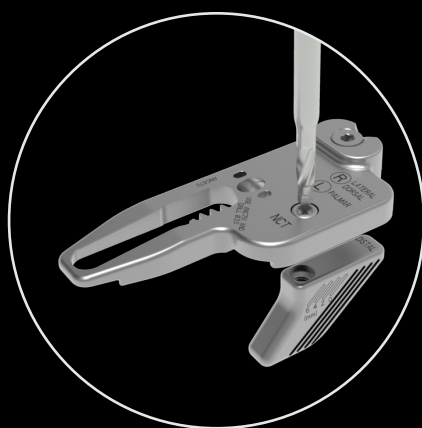

ALIANS ULNA 3/3 ULNAR SHORTENING OSTEOTOMY PLATE

MONOAXIAL LOCKING SYSTEM
ONECLIP®

- ▶ Rack-and-pinion compression device
- ▶ Stabilization transfixation screw / compression screw
- ▶ Low-profile locking plate

ALIANS ULNA 3 / 3

Indications: The implants of the Alians Ulna range are intended for ulnar shortening osteotomies in adults.





Contraindications:

- Serious vascular deterioration, bone devitalization.
- Pregnancy.
- Acute or chronic local or systemic infections.
- Lack of musculo-cutaneous cover, severe vascular deficiency affecting the concerned area.
- Insufficient bone quality preventing a good fixation of the implants into the bone.
- Muscular deficit, neurological deficiency or behavioral disorders, which could submit the implant to abnormal mechanical strains.
- Allergy to one of the materials used or sensitivity to foreign bodies.
- Serious problems of non-compliance, mental or neurological disorders, failure to follow post-operative care recommendations.
- Unstable physical and/or mental condition.

IMPLANT TECHNICAL FEATURES

- **Anatomically contoured implant:** the edges and tips of the implant are rounded to minimize soft tissue irritation.
- **Marks** appearing on the implant :
 - **Proximal and distal** ends
 - **Graduations for checking** compression level

→ MONOAXIAL FIXATION

-  • Ø3.5 mm standard cortical screw for proximal oblong hole (CT3.5Lxx)
-  • Ø3.5 mm locking screw (SOT3.5Lxx)
-  • Ø2.8 mm standard cortical screw for pre-angled central hole (CT2.8Lxx): stabilization screw
-  • Ø2.8 mm lag screw for pre-angled central hole (QBT2.8Lxx) : compression screw

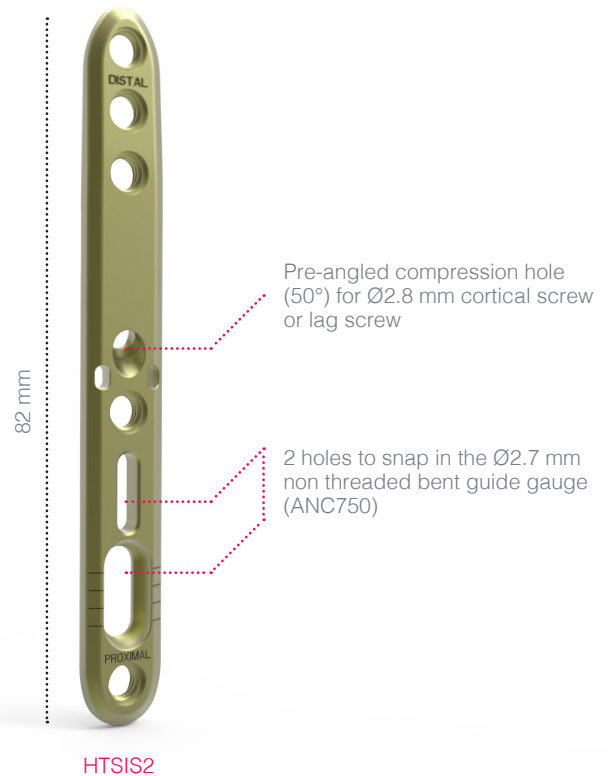

MONOAXIAL LOCKING SYSTEM

→ FEATURES

- The threaded sections under the screw head and inside the hole have strictly the **same characteristics** (1) :
 - Cylindrical internal thread profile,
 - Cylindrical external thread profile,
- Screw head cap (2),
- Plate and screw made from the same material: titanium alloy.

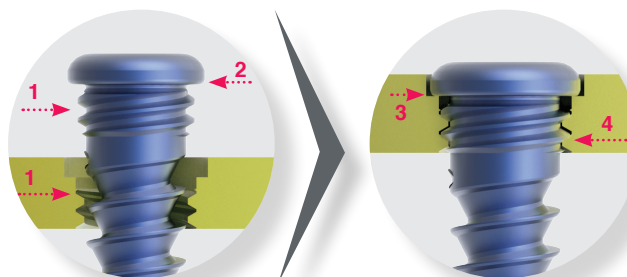

→ RESULTS

- **Low profile construct:**
 - The screw head reaches a mechanical stop in the slot, insuring the locking (3),
 - The screw head is buried in the plate.
- Construct limiting the risk of cold welding
- Construct allowing an optimized coaptation of both profiles when locking (4).

CUTTING GUIDE AND COMPRESSION DEVICE

COMPONENTS

- 2 blocks (ANC670 and ANC671) allowing to manage the operated side (right or left) and the approach (lateral, dorsal or palmar/volar).

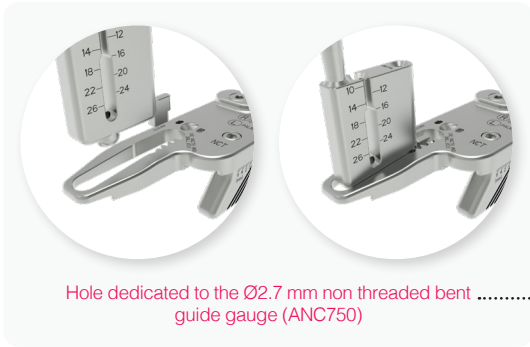

Block - Alians
Ulna plate fixation
screw

Pin holes

Rack-and-pinion
system allowing
optimal compression
of the osteotomy sites

The block should be chosen according to:

- The side: right or left
- The selected approach: lateral, dorsal or palmar (volar)

Pre-oriented hole for
transfixation screw in
order to be perpendicular
to the cut

Block - cutting guide
fixation screw

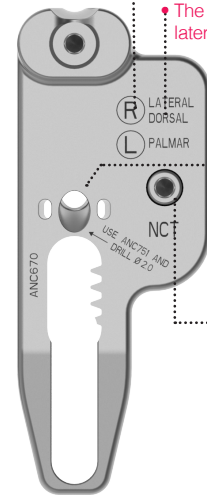
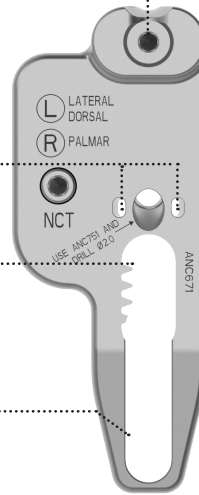

- 2 cutting guides (ANC171/1 and ANC171/2) enabling 2 to 6 mm resections. The indication 'DISTAL' is present on each cutting guide to ensure an appropriate positioning on the block.

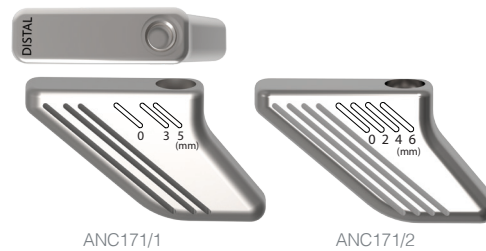

ASSEMBLING

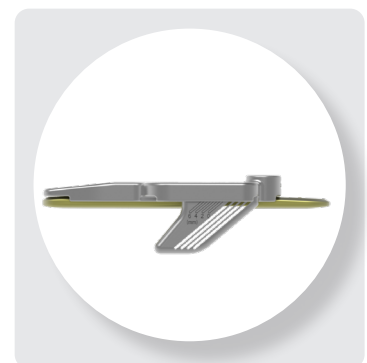

- Choose one of the two blocks (ANC670 or ANC671) depending on the operated side (left or right) and the selected approach (lateral, dorsal or palmar/volar).
The illustration above presents a palmar/volar approach on a left ulna.
- To perform the resection, adjust and secure the cutting and compression device to the plate. Insert and tighten the screw of the block into the appropriate hole of the plate using the screwdriver part of the 2-in-1 instrument (ANC083C).

FINAL RESULT

Choose the appropriate cutting guide (ANC171/1 or ANC171/2) depending on the resection to perform.

Assemble the cutting guide and the block by fastening the preassembled screw with the screwdriver part of the 2-in-1 instrument (ANC083C).

SURGICAL TECHNIQUE

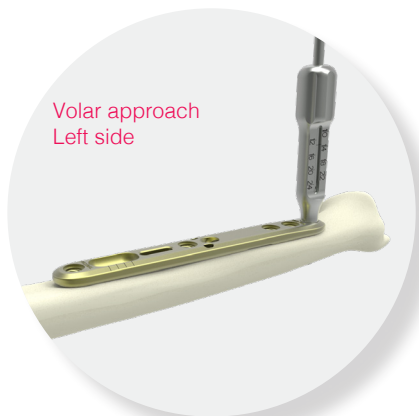

1. Position the plate. In the most distal hole, drill (Ø2.7 mm) (ANC089C) and directly read the drilling depth on the Ø2.7 mm threaded guide gauge (ANC186).

NB : It is possible to position the plate previously assembled with the cutting guide and compression device.

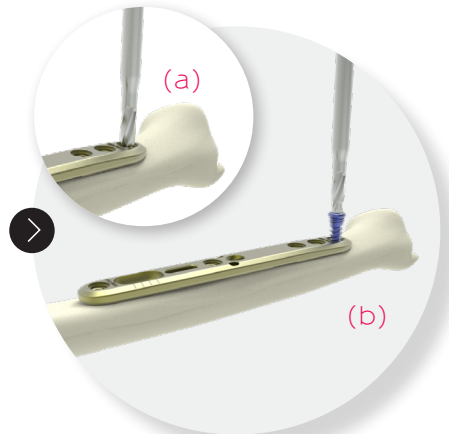

2.a. To ease the insertion of the Ø3.5 mm locking screw (SOT3.5Lxx) use the countersink part of the 2-in-1 instrument (ANC083C) to widen the previously drilled first cortex.

2.b. Insert a Ø3.5 mm locking screw (SOT3.5Lxx) using the screwdriver part of the 2-in-1 instrument (ANC083C).



3. Snap the Ø2.7 mm non threaded bent guide gauge (ANC750) in the plate oblong hole.

In the proximal hole of the instrument, perform the Ø2.7 mm drilling (ANC089C) and directly read the drilling depth.

NB : In case where the block is assembled with the plate, the Ø2.7 mm non threaded bent guide gauge (ANC750) can be snapped in through the block (see § "components").

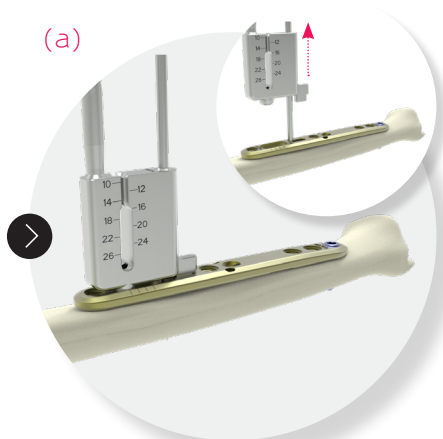

4.a. In the distal hole of the instrument (ANC750), insert a Ø2.2 mm pin (33.0222.120) using the bicortical fixation method. Remove the non threaded bent guide gauge (ANC750) by sliding it along the Ø2.2 mm pin (33.0222.120).

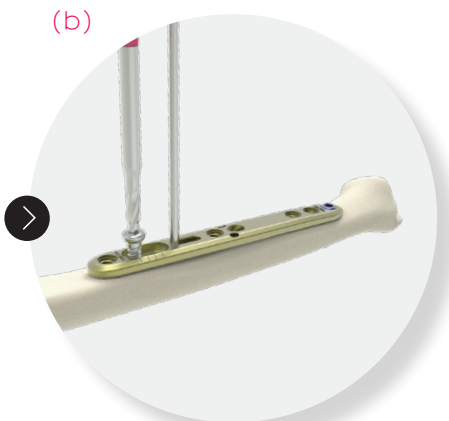

4.b. Insert a Ø3.5 mm cortical screw (CT3.5Lxx) using the bicortical fixation method in the proximal part of the oblong hole using the screwdriver part of the 2-in-1 instrument (ANC083C).

The cortical screw (CT3.5Lxx) and the Ø2.2 mm pin (33.0222.120) help to perfectly align both proximal and distal parts during compression.

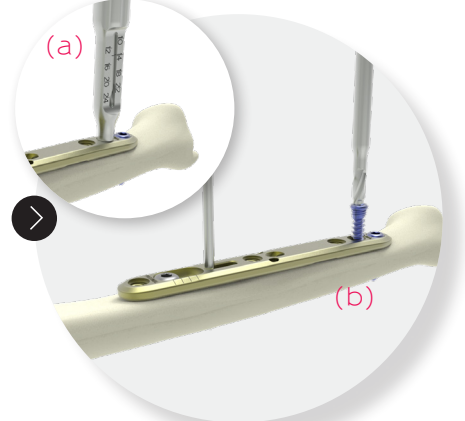

5.a. In the second distal hole of the plate, drill (Ø2.7 mm) (ANC089C) using the Ø2.7 mm threaded guide gauge (ANC186).

5.b. Insert a Ø3.5 mm locking screw (SOT3.5Lxx) using the screwdriver part of the 2-in-1 instrument (ANC083C).

NB : In case where the block is assembled with the plate, the Ø2.7 mm threaded guide gauge (ANC186) can be locked on the second most distal hole without conflict with the block.



6. Assemble the cutting and compression device (see, § "Assembling") and fix it into the distal hole the closest to the osteotomy site.

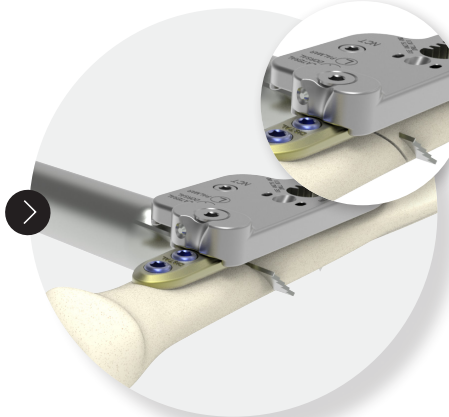

7. Perform the two cuts necessary for the ulnar shortening osteotomy using the cutting guide at **graduation 0 at first**. Then at the graduation corresponding to the required resection. The resection is thus made by two oblique saw cuts.

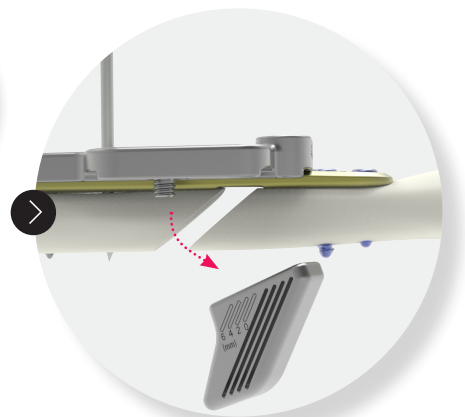

8. Remove the cutting guide (ANC171/1 or ANC171/2) to pull out the resected bone fragment.

SURGICAL TECHNIQUE OPTION 1: STABILIZATION STANDARD CORTICAL SCREW

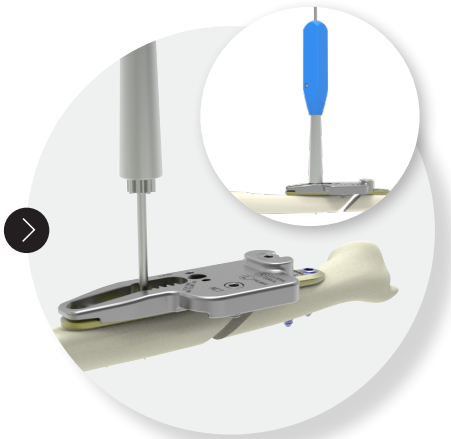

9. Slide the cannulated handle (ANC669) along the Ø2.2 mm pin (33.0222.120) and into the rack-and-pinion section of the block.

⚠ Unscrew the cortical screw (CT3.5Lxx) of only half a turn so that the plate may be slid.

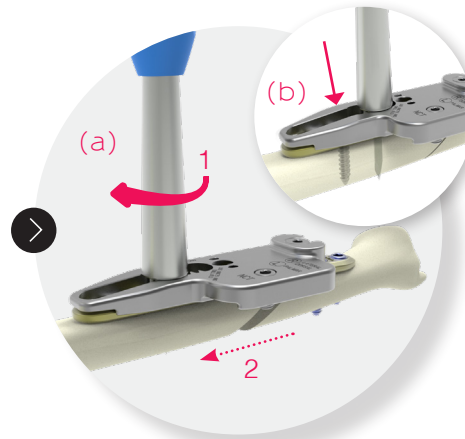

10.a. Rotate the cannulated handle to perform compression of the osteotomy site.

10.b. While maintaining the compression, tighten up the Ø3.5 mm cortical screw (CT3.5Lxx) into the oblong hole.

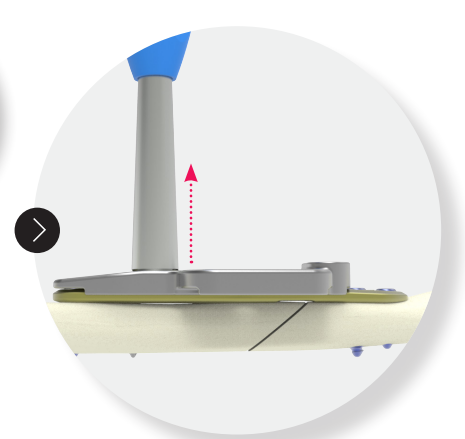

11. Remove the cannulated compression handle (ANC669) by sliding it along the Ø2.2 mm pin (33.0222.120).

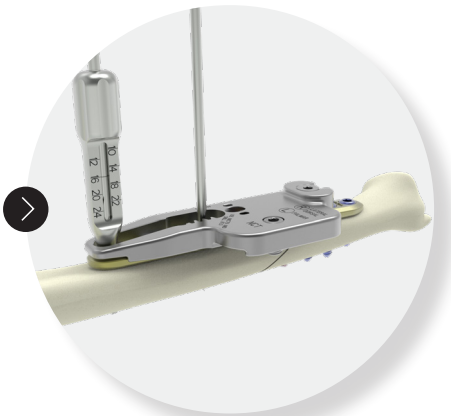

12. Into the most proximal hole, drill (Ø2.7 mm) (ANC089C) using the Ø2.7 mm guide gauge (ANC186).

Insert a Ø3.5 mm locking screw (SOT3.5Lxx) Remove the Ø2.2 mm pin (33.0222.120).

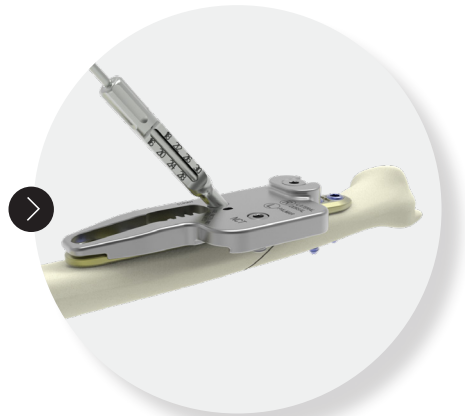

13. Position the Ø2.0 mm non threaded guide gauge (ANC751) into the pre-angled (50°) hole of the block (ANC670/671), drill (Ø2.0 mm) (ANC088) and directly read the drilling depth on the guide gauge (ANC751).

⚠ Ø2.7 mm drill **must not be used** into the pre-angled hole (ANC089C).

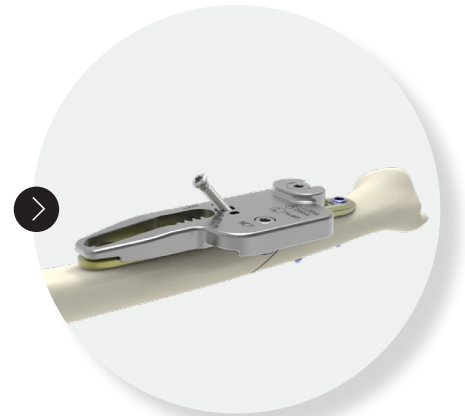

14. Insert a Ø2.8 mm cortical screw (CT2.8Lxx) directly through the block using the appropriate screwdriver (ANC082).

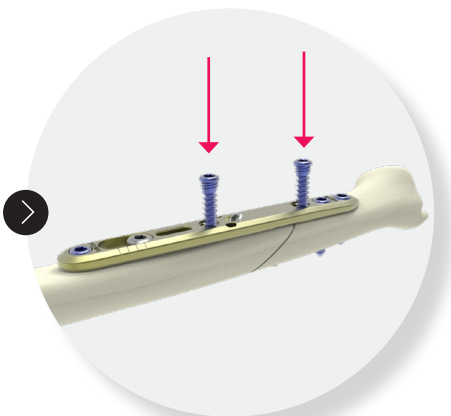

15. Remove the block and complete the procedure by inserting the last two Ø3.5 mm locking screws (SOT3.5Lxx) into the remaining locking holes.

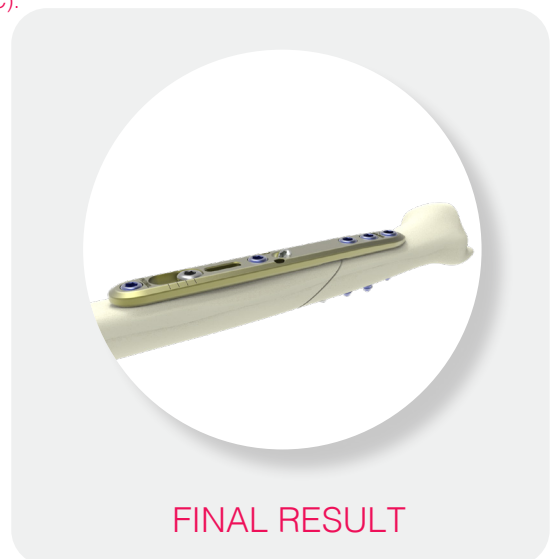

SURGICAL TECHNIQUE OPTION 2: COMPRESSION LAG SCREW

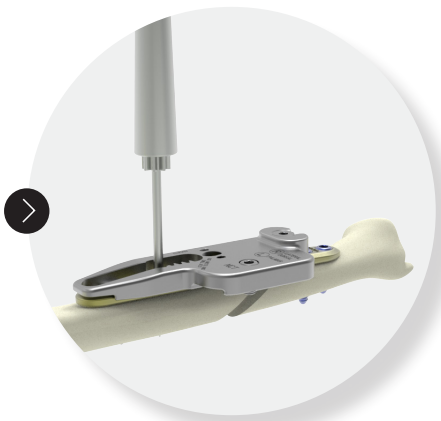

9. Slide the cannulated compression handle along the Ø2.2 mm pin (33.0222.120) and into the rack-and-pinion section of the block.

⚠ Unscrew the cortical screw (CT3.5Lxx) of only half a turn so that the plate may be slid.

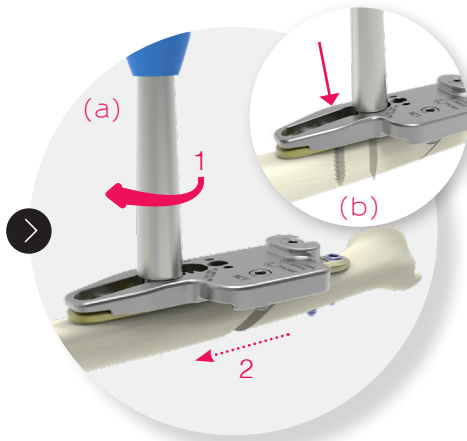

10.a. Rotate the cannulated handle to perform compression of the osteotomy site.

10.b. While maintaining the compression, tighten the Ø3.5 mm cortical screw (CT3.5Lxx) into the oblong hole.

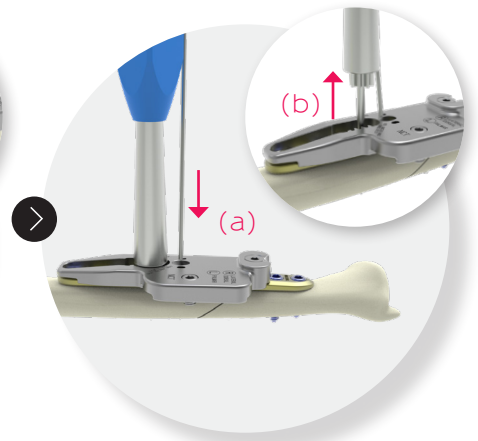

11.a. Insert a Ø1.6 mm pin (33.0216.100) into one of the appropriate side holes for stabilization of the assembly. **Make sure to insert the pin into the proximal part of the pin hole in order to allow compression.**

11.b. Then remove both the cannulated compression handle (ANC669) and the Ø2.2 mm pin (33.0222.120).

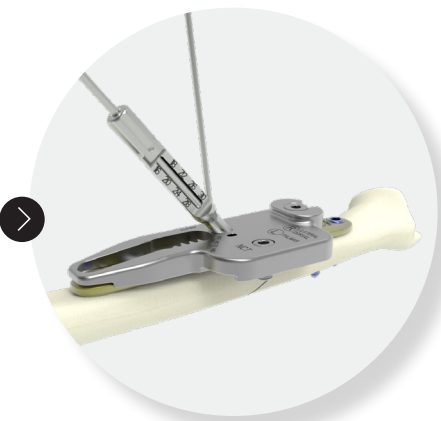

12. Position the Ø2.0 mm non threaded gauge (ANC751) into the pre-angled (50°) hole of the block and perform the drilling (Ø2.0 mm) (ANC088). Read directly the drilling depth on the Ø2.0 mm non threaded guide gauge (ANC751).

⚠ Ø2.7 mm drill **must not be used** into the preangled hole (ANC089C).

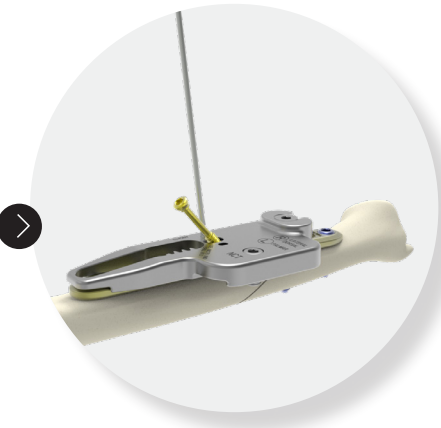

13. Insert a Ø2.8 mm lag screw (QBT2.8Lxx) directly through the block using the appropriate screwdriver (ANC082).

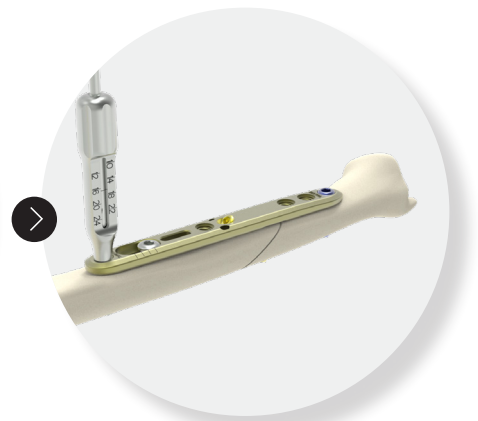

14. Remove the Ø1.6 mm pin and the block. Into the most proximal hole, drill (Ø2.7mm) (ANC089C) using the Ø2.7 mm threaded gauge (ANC186). Insert a Ø3.5 mm locking screw (SOT3.5Lxx) using the screwdriver part of the 2-in-1 instrument (ANC083C).

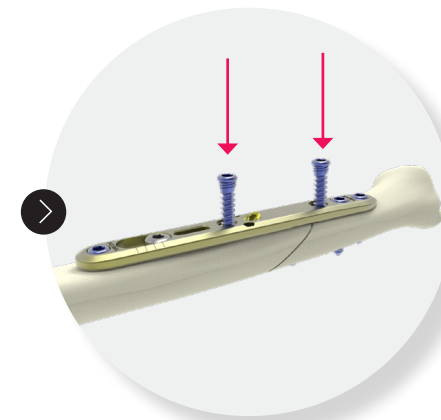

15. Complete the procedure by inserting the last two Ø3.5 mm locking screws (SOT3.5Lxx) into the remaining locking holes.

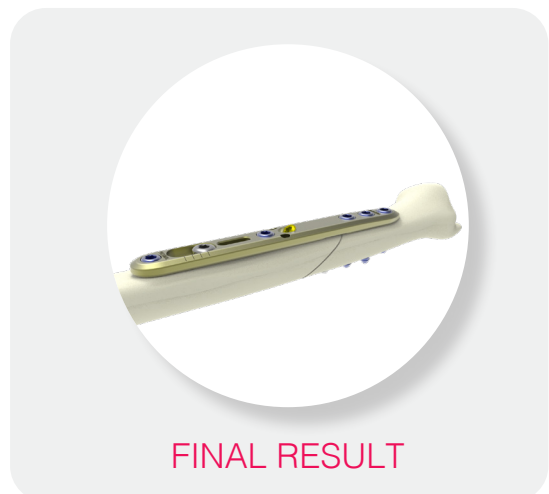

FINAL RESULT

IMPLANTS REFERENCES

ALIANS ULNA PLATE 3/3

Ref.	Description
HTSIS2	Symmetrical osteotomy plate for Ulna – Size 2

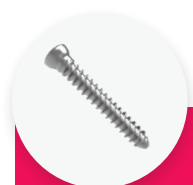

Ø2.8 mm STANDARD CORTICAL SCREW*

Ref.	Description
CT2.8L16	Standard cortical screw - Ø2.8 mm - L16 mm
CT2.8L18	Standard cortical screw - Ø2.8 mm - L18 mm
CT2.8L20	Standard cortical screw - Ø2.8 mm - L20 mm
CT2.8L22	Standard cortical screw - Ø2.8 mm - L22 mm
CT2.8L24	Standard cortical screw - Ø2.8 mm - L24 mm

* Non anodized.

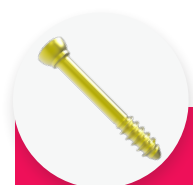

Ø2.8 mm LAG SCREW*

Ref.	Description
QBT2.8L18	Lag screw - Ø2.8 mm - L18 mm
QBT2.8L20	Lag screw - Ø2.8 mm - L20 mm
QBT2.8L22	Lag screw - Ø2.8 mm - L22 mm
QBT2.8L24	Lag screw - Ø2.8 mm - L24 mm

* Yellow anodized.

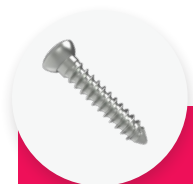

Ø3.5 mm STANDARD CORTICAL SCREW*

Ref.	Description
CT3.5L10	Standard cortical screw Ø3.5 mm - L10 mm
CT3.5L12	Standard cortical screw Ø3.5 mm - L12 mm
CT3.5L14	Standard cortical screw Ø3.5 mm - L14 mm
CT3.5L16	Standard cortical screw Ø3.5 mm - L16 mm
CT3.5L18	Standard cortical screw Ø3.5 mm - L18 mm
CT3.5L20	Standard cortical screw Ø3.5 mm - L20 mm
CT3.5L22	Standard cortical screw Ø3.5 mm - L22 mm
CT3.5L24	Standard cortical screw Ø3.5 mm - L24 mm
CT3.5L26	Standard cortical screw Ø3.5 mm - L26 mm

* Non anodized.

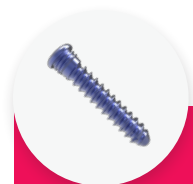

Ø3.5 mm LOCKING SCREW*

Ref.	Description
SOT3.5L10	Locking screw Ø3.5 mm - L10 mm
SOT3.5L12	Locking screw Ø3.5 mm - L12 mm
SOT3.5L14	Locking screw Ø3.5 mm - L14 mm
SOT3.5L16	Locking screw Ø3.5 mm - L16 mm
SOT3.5L18	Locking screw Ø3.5 mm - L18 mm
SOT3.5L20	Locking screw Ø3.5 mm - L20 mm
SOT3.5L22	Locking screw Ø3.5 mm - L22 mm
SOT3.5L24	Locking screw Ø3.5 mm - L24 mm
SOT3.5L26	Locking screw Ø3.5 mm - L26 mm

* Blue anodized.

Remark:

Please note that all implants are also available in sterile packaging. An 'ST' code is added at the end of the reference. e.g. « CT3.5L10-ST »

INSTRUMENT REFERENCES

ALIANS ULNA 3/3 INSTRUMENTS		
Ref.	Description	Qty
ANC082	2.0 mm quick coupling hexagonal prehensor screwdriver	2
ANC083C	2-in-1 : 2.5 mm hexagonal prehensor screwdriver – Ø3.5 mm countersink	2
ANC084	Ø2.8 mm quick coupling countersink	1
ANC088	Ø2.0 mm quick coupling drill bit – L125 mm	1
ANC089C	Ø2.7 mm quick coupling drill bit - L125 mm	2
ANC124	Length gauge for Ø3.5 mm cortical screws	1
ANC171/1	Cutting guide – 3-5 mm	1
ANC171/2	Cutting guide – 2-4-6 mm	1
ANC186	Ø2.7 mm threaded guide gauge for Ø3.5 mm screws	2
ANC191	Ø2.7 mm non threaded bent guide gauge for Ø3.5 mm screws	1
ANC349	15 cm verbrugge forceps	2
ANC350	Ø4.5 mm AO quick coupling handle – Size 1	2
ANC669	Ø2.6 mm cannulated handle for Ulna cutting guide	1
ANC670	Left long block for Ulna plate	1
ANC671	Right long block for Ulna plate	1
ANC750	Ø2.7 mm non threaded bent guide gauge – Ø2.5 mm pin guide	1
ANC751	Ø2.0 mm non threaded guide gauge for Ulna	1
33.0216.100	Pin Ø1.6 L100	2
33.0222.120	Pin Ø2.2 L120	2

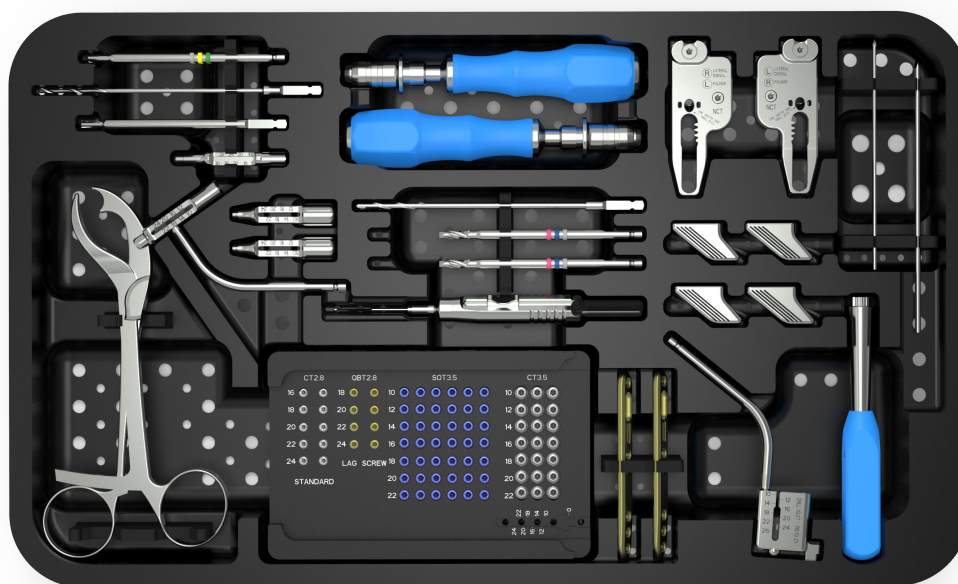

ANC796

REMOVAL KIT

If you have to remove ALIANS ULNA implants, make sure to order the **Newclip Technics** removal set which includes the following instruments:

- ANC082 or ANC103 for Ø2.8 mm screws
- ANC107 or ANC016 for Ø3.5 mm screws
- ANC350: Ø4.5 mm AO quick coupling handle - Size 1
- ANC351: Ø4.5 mm AO quick coupling handle - Size 2

The information presented in this brochure is intended to demonstrate a NEWCLIP TECHNICS product. Always refer to the package insert, product label and/or user instructions before using any NEWCLIP TECHNICS product. Surgeons must always rely on their own clinical judgment when deciding which products and techniques to use with their patients. Products may not be available in all markets. Product availability is subject to the regulatory or medical practices that govern individual markets. Please contact your NEWCLIP TECHNICS representative if you have questions about the availability of NEWCLIP TECHNICS products in your area.



NEWCLIP TECHNICS
PA de la Lande Saint Martin - 45 rue des Garottières
44115 Haute Goulaine (France)
Tél.: +33 (0)2 28 21 23 25 - Fax: +33 (0)2 40 63 68 37
orders@newcliptechnics.com
www.newcliptechnics.com

NEWCLIP USA
642 Larkfield Center,
Santa Rosa CA 95403, USA
Phone: +1 707 230 5078
customerservice@newclipusa.com
www.newclipusa.com

NEWCLIP TECHNICS GmbH
Pröllstraße 11,
D-86157 Augsburg, Deutschland
Phone: +49 (0)821 650 749 40
info@newclipgmbh.com
www.newclipgmbh.de

NEWCLIP TECHNICS Australia
Forest Central Business Park
Building 10 Level 1, 49 Frenchs Forest
Rd, Frenchs Forest 2086, Australia
Phone: +61 (0)2 81 886 110
solutions@newclipaustralia.com
www.newcliptechnics.com